



P.O. Box 890 • Silverton, Oregon 97381 • (503) 873-5794

MODEL H50

HEAVY DUTY RUBBER LOOP

Designed for easy installation in a saw cut

- Ultimate wire protection; loop will last as long as other equipment at intersection.
- Excellent moisture protection.
- Easy, inexpensive installation when taped down and paved over.
- No need to damage new pavement to sawcut in loops.
- Shifts and conforms to pavement movement.
- Direct burial in gravel.
- Minimal joints reduce weak points.

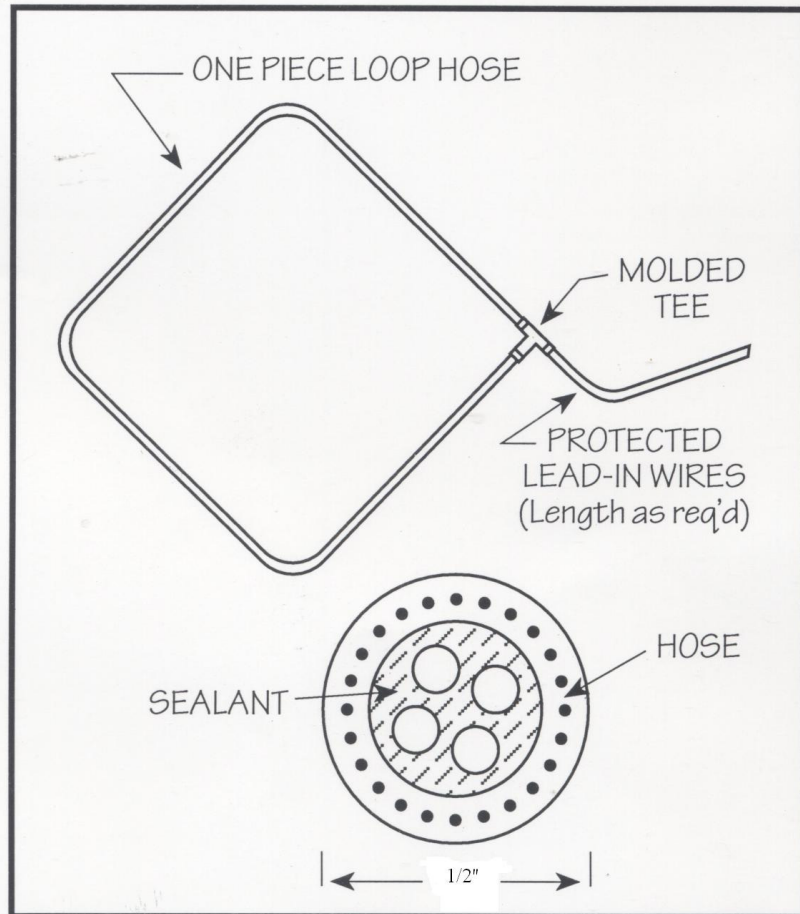
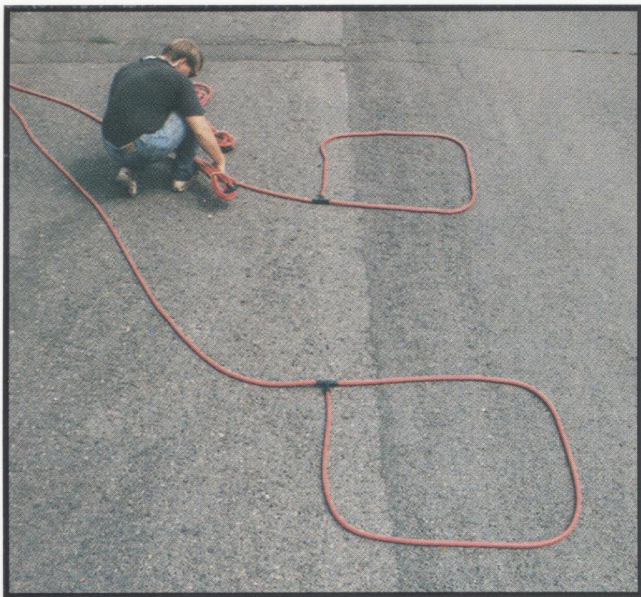

SPECIFICATIONS

- ✓ Loop and lead-in constructed with $\frac{3}{8}$ " heavy duty reinforced rubber hose. (Class A oil resistant)
- ✓ Tee constructed of heavy duty high temperature synthetic rubber.
- ✓ Standard wire is 18 gauge TFFN.
- ✓ Loop and Lead-in are filled for greater durability and for extra moisture resistance.
- ✓ Each loop custom built to your specifications. (size, turns and lead lengths)

Contact:
sales@de-tech-mfg.com
Greg@de-tech-mfg.com